



WEBOX®

Thermoboxes 800X400



light
and handy



exceptionally
durable



great shock
absorption



protect products
from light



protect products
from drying

All boxes are PZH-Certified (Polish National Institute of Hygiene).

DESCRIPTION

Thermobox WEBOX® 800x400 is made of expandable polystyrene (EPS) in molding technology.

These lightweight but practical, high-quality EPS boxes are designed to protect products in transport and storage. Hygienic, with excellent thermal insulation properties, they are especially recommended for foods such as fish, seafood and meats.



SALES DEPARTMENT

If you want to know our products,
need an offer, webox for testing,
we are at your disposal.

CONTACT

+48 880 599 163
webox@yetico.com
yetico.com

WEBOX®

BENEFITS WEBOX®

WEBOX® is designed to provide multiple advantages for users. It is light and handy, but at the same time durable so that absorbs shocks well. It protects products from light, moisture, low and high temperatures and prevents drying out. It will work well during long journeys, even by a few day transport. WEBOX® is suitable for stacking. Thermoboxes can be printed on request.



DRAIN SYSTEMS



DRAIN HOLES

Each of the boxes can be produced in a version without and with drain holes



DRAIN SPACER

Each box can be equipped with the removable spacer, that drain excess water coming from products.



APPLICATION CONSIDERATIONS

- Service temperature: for products with temperatures up to + 70°C and down to -18°C.
- Storage: store in dry and sun-free rooms at the temperature of 5-35°C.
- The containers should not be used in ovens and not used as a toy.

HEALT AND SAFETY, ENVIRONMENT

According to the REACH regulation, WEBOX® packaging does not contain harmful substances. Used packaging is 100% recyclable, therefore it is recommended to recycle it.

STANDARDS AND QUALITY

All Yetico production plants operate on the basis of procedures that enable product standardization. This ensures repeatability of technical parameters. We use only raw materials from reputable companies for production. The products are manufactured in accordance with applicable standards and have the appropriate approvals, enabling free turnover of goods. We operate according to the assumptions of the Integrated Quality Management System, in accordance with the standards: PN-EN ISO 9001, PN-EN ISO 14001, PN-N-45001.



Groupe	Product type	External dimensions without lid [mm]	External dimensions with lid [mm]	Internal dimensions [mm]	Content weight [kg]	Items per layer [units]
400x300	webox 2/400x300x90	400x300x90	400x300x107	360x260x65	2	320
	webox 3/400x300x108	400x300x108	400x300x125	360x260x80	3	260
	webox 5/400x300x130	400x300x130	400x300x145	360x260x105	5	220
	webox 5+/400x300x160	400x300x160	400x300x170	360x260x125	5	180
500x300	webox 10/500x300x200	500x300x200	500x300x215	456x256x175	10	112
600x400	webox 8/600x400x125	600x400x125	600x400x145	545x345x100	8	110
	webox 10/600x400x145	600x400x145	600x400x165	545x345x120	10	100
	webox 15/600x400x175	600x400x175	600x400x195	545x345x150	15	80
	webox 20/600x400x195	600x400x195	600x400x215	545x345x170	20	70
	webox 25/600x400x275	600x400x275	600x400x295	545x345x250	25	50
800x400	webox 20/800x400x180	800x400x180	800x400x205	745x345x150	20	48
	webox 25/800x400x200	800x400x200	800x400x225	745x345x170	25	42
	webox 30/800x400x280	800x400x280	800x400x305	745x345x250	30	30

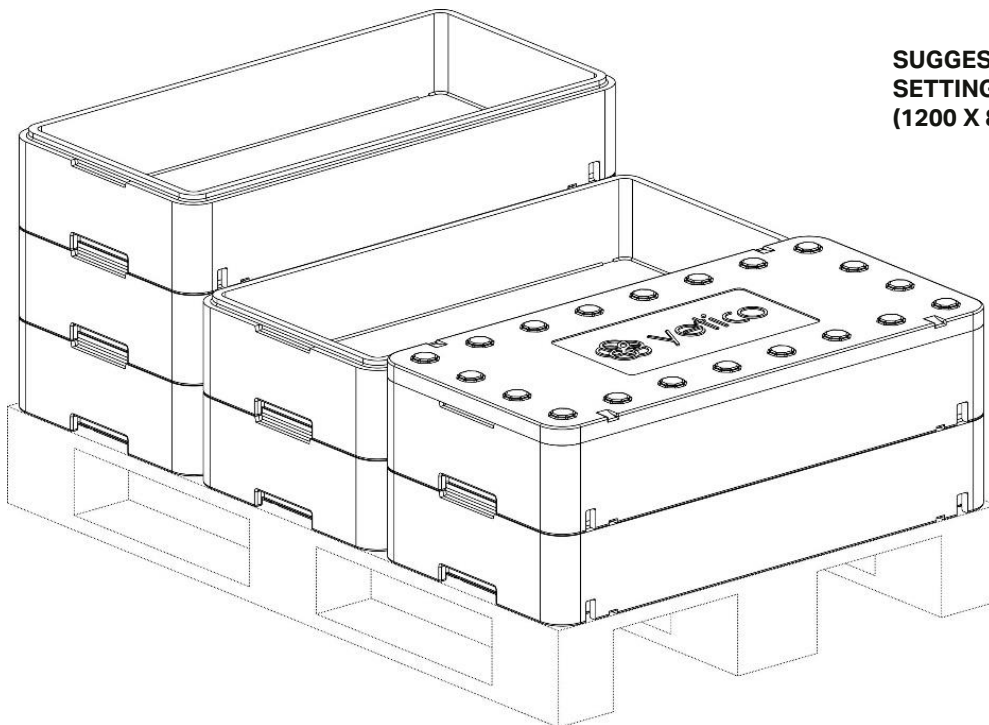

SUGGESTION OF WEBOX 800X400 SETTING ON EUROPALET (1200 X 800 MM).



DOCUMENTS

Declaration of Conformity
No. 01/EPS/2024 for thermal
insulation containers.

Conformity assessment certificate
No. 20/2022.

HEADQUARTERS

YETICO S.A.
Towarowa 17a
10-416 Olsztyn

+48 89 538 78 11
yetico@yetico.com
www.yetico.com

SALES DEPARTMENT

+48 880 599 163
webox@yetico.com

WEBBOX®